

The following procedure is a supplement to other documentation supplied with this equipment and will guide the user in properly wiring the A1000 and motor. It will also show the user how to configure the A1000 in open loop vector mode for a general purpose application.

**Danger: Improper wiring can and will cause bodily harm as well as damage to the equipment.**

When installing the system, be sure to follow good wiring practices and all applicable codes. Ensure that the mounting of components is secure and that the environment, such as extreme dampness, poor ventilation, etc. will not cause system degradation.

**Please read this cheat sheet and other documentation provided with the A1000 thoroughly before attempting any installation.**

## Step 1 A1000 Model Identification and Mounting

To make sure you received the correct model, it is essential to verify the A1000 nameplate with your order and make sure the A1000 has the correct rating so it can be used with your motor. Please check the nameplate information as shown in the example below.

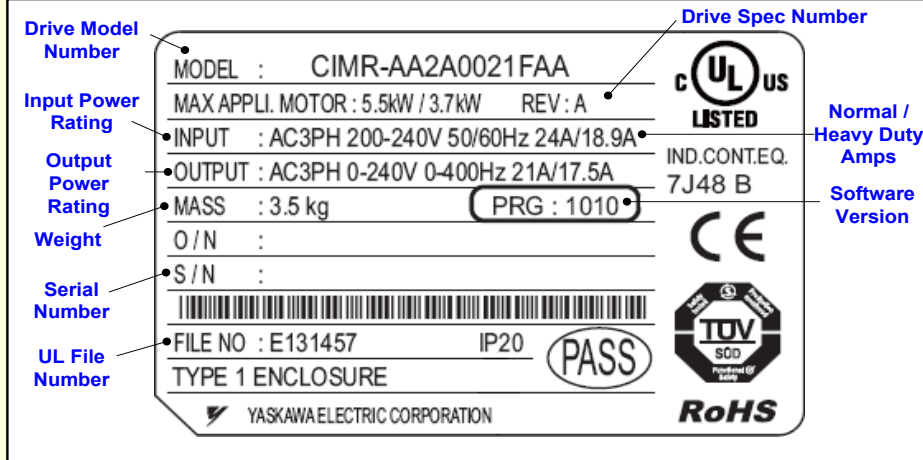

- Check that the available power will meet the **input power** requirements.
- Ensure that the **output power** from the A1000 is compatible with the motor requirements.
- In the case of systems with more than one A1000, follow the above procedure for each A1000 and motor.

### Mounting the A1000

The mounting of the A1000 is extremely important regarding environment and accessibility. Depending on your system, there are various models available and the mounting dimensions (footprint) may be different. Because the mounting procedure is fairly extensive, it is beyond the scope of this document; the user is referred to the A1000 User Manual (Document No. SIEP C710606 21A) received with the A1000, **Section 2.2 Mechanical Installation**. Match the model that you received and follow the procedure described in the manual to ensure a safe and functional installation. In cases where the system has more than one A1000, refer to the proper clearances required for adequate ventilation. *Please pay particular attention to:*

- The clearances to be maintained around the enclosure for adequate ventilation.
- The environmental specifications such as avoiding excessive dampness, extreme temperatures, chemical exposure, corrosive areas, etc. to avoid damage to the equipment and to maintain safety.

### Removing and Attaching the Terminal Cover

Improper removal of the A1000 terminal cover as well as front cover can cause extensive damage to the A1000. To avoid damage to these items, please pay particular attention to the A1000 User Manual, Document No. SIEP C710606 21A, Section 3.5, **Removing and Attaching the Terminal Cover**.

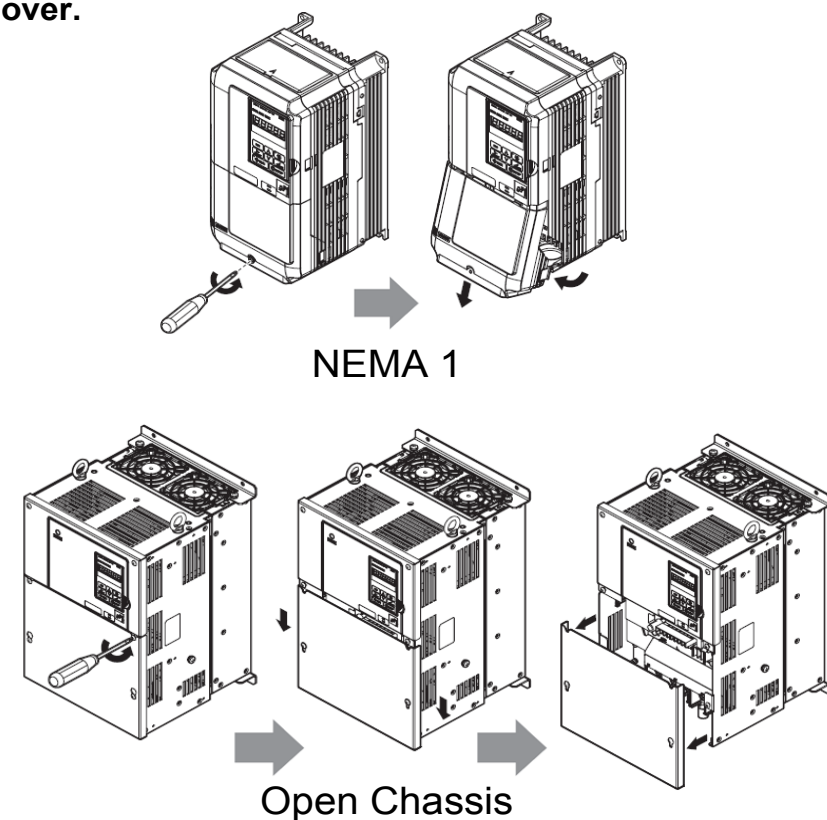

## Step 2 Connect Motor and Line Power

Fig. 1 & 2 below show the electrical connections for the input power and motor terminals for various A1000 models. Select the proper diagram for the model you are installing (see Step 1). **WITH POWER OFF** make the appropriate connections.

**Make sure to follow good wiring practices and all applicable codes. Ensure that the equipment is grounded properly as shown in fig. 1**

**! DANGER; LETHAL VOLTAGES ARE PRESENT- Before applying power to the A1000, ensure that the terminal cover is fastened and all wiring connections are secure. After the power has been turned OFF, wait at least five minutes until the charge indicator extinguishes completely before touching any wiring, circuit boards or components.**

**WARNING DO NOT CONNECT ANY OF THE FOLLOWING TERMINALS TO EARTH GROUND**

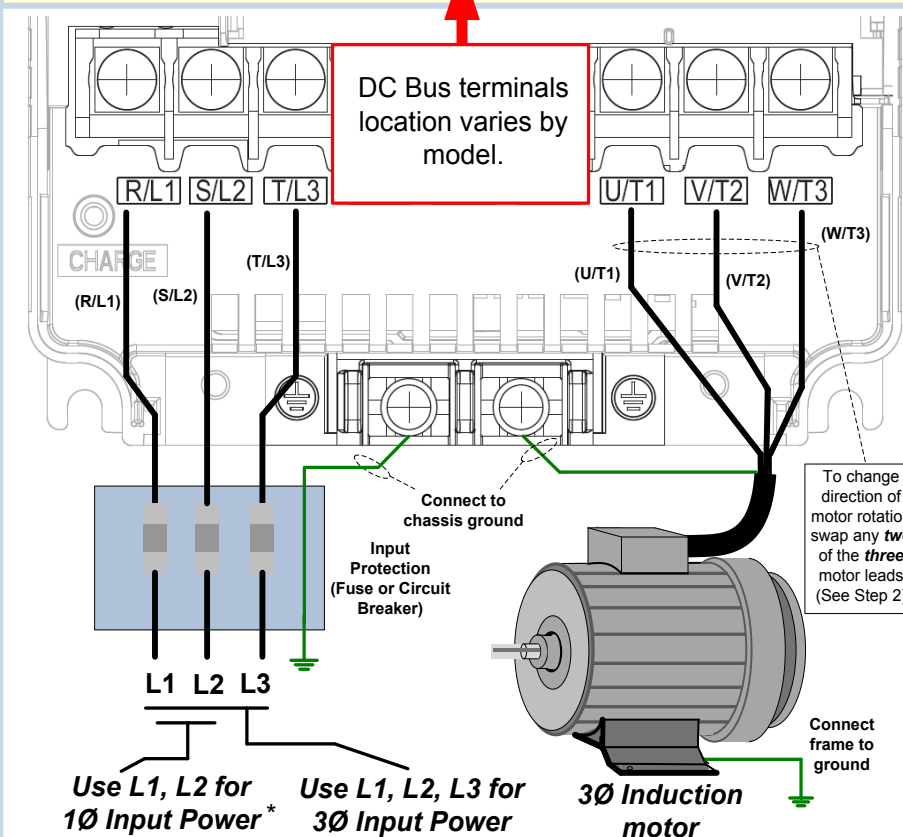
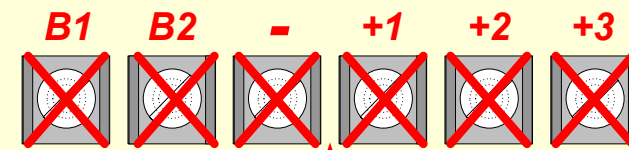

Fig. 1 Input Power and Output Motor Electrical Connections for Models: 2\_0004 - 2\_0056, 4\_0002 - 4\_0044 and 5\_0003 - 50011

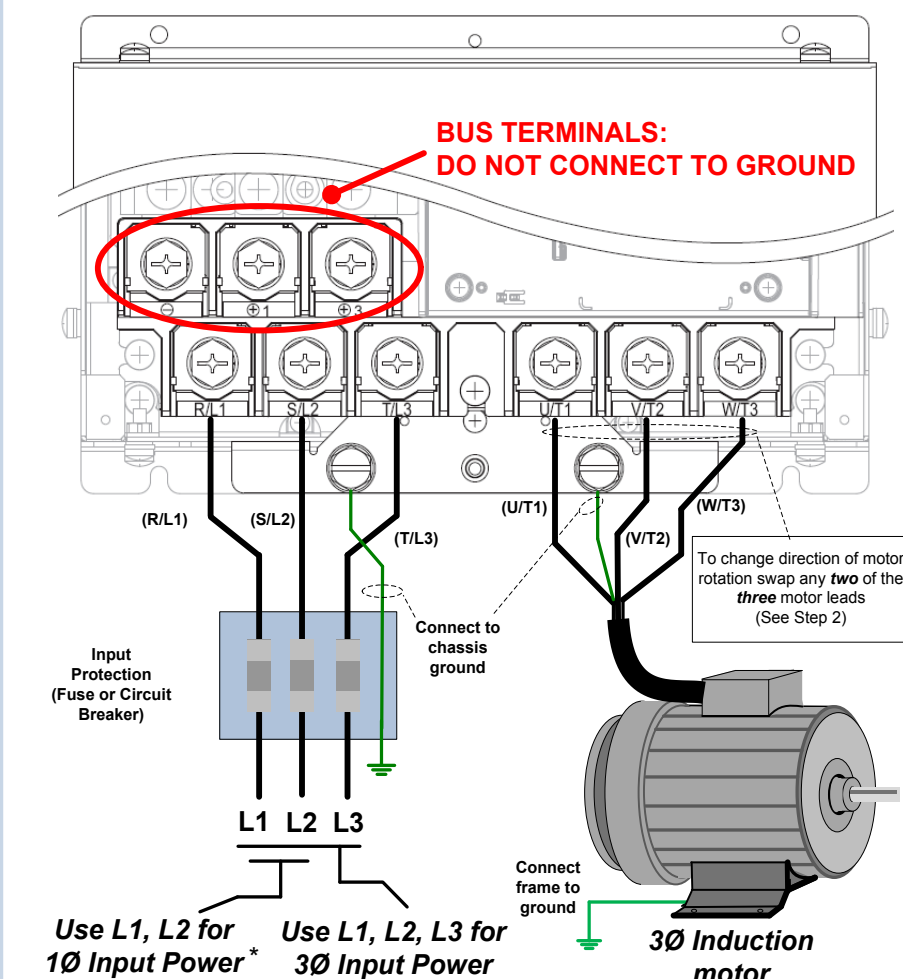

Fig. 2 Input Power and Output Motor Electrical Connections for Models: 2\_0110 & Larger and 4\_0058 & Larger

\* Make sure the A1000 has been properly sized for single phase input power. For best performance, the drive input supply voltage must be at least equal to or greater than the motor rated voltage.

## Step 3 Check Motor Direction (Motor uncoupled from Load)

In this step the motor is checked for proper direction and operation. This test is to be performed solely from the digital operator. Apply power to the A1000 after all the electrical connections have been made and protective covers have been re-attached. At this point, **DO NOT RUN THE MOTOR**, the Digital Operator should display as shown in Fig. 3.



Fig. 3 Digital Operator

### Motor Rotation Test

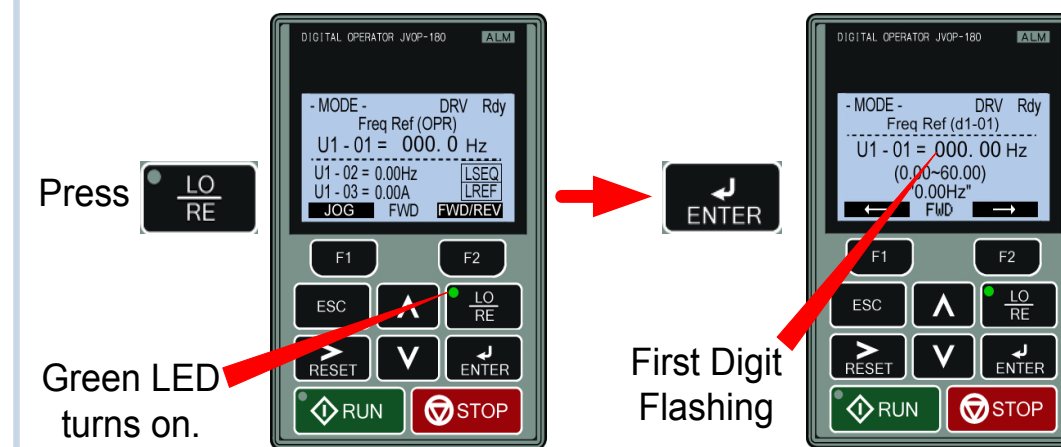

Next, press **RESET** to move the cursor one position to the right and **UP** to increase the frequency reference (d1-01) to 10.00 Hz. Press **ENTER** to save frequency reference.

Next, press **RUN** on the Digital Operator. The motor should now be operating at low speed running in the correct forward (clockwise) direction.

Next, press **STOP** on the Digital Operator.

**If motor rotation is not correct, then either reverse "Phase Order" using parameter b1-14 or power down the drive, wait five minutes and swap 2 motor leads.**

**! DANGER**  
**After the power has been turned OFF, wait at least five minutes until the charge indicator extinguishes completely before touching any wiring, circuit boards or components.**

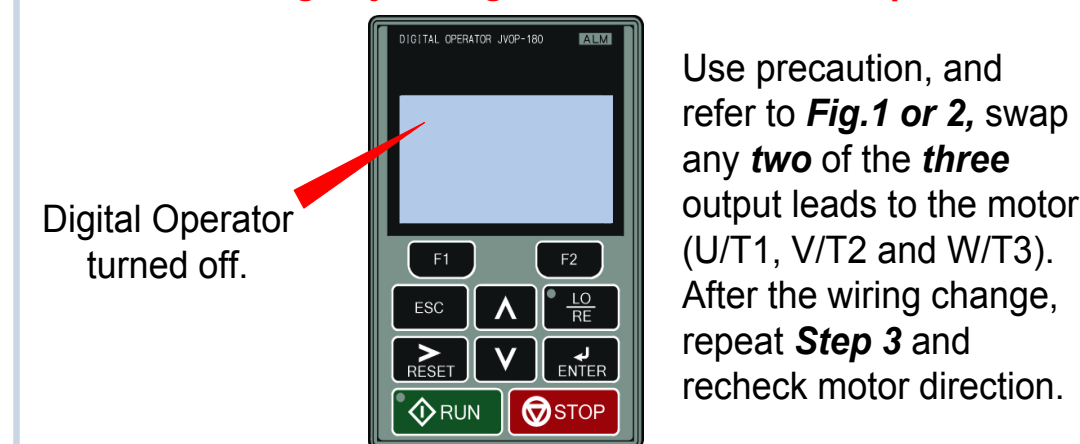

Digital Operator turned off.

Use precaution, and refer to Fig. 1 or 2, swap any **two** of the **three** output leads to the motor (U/T1, V/T2 and W/T3). After the wiring change, repeat **Step 3** and recheck motor direction.

## Step 4 Rotational Auto-tuning (De-couple Motor from Load)

In this step the A1000 is setup for use with the motor. Make sure all protective covers have been re-attached then apply power to the A1000. **DO NOT RUN THE MOTOR.**

From the main reference press **DOWN** once until the Digital Operator shows the Auto-Tuning menu then press **ENTER**



Press **UP** once until the Digital Operator shows parameter T1-02 Mtr Rated Power then press **ENTER**

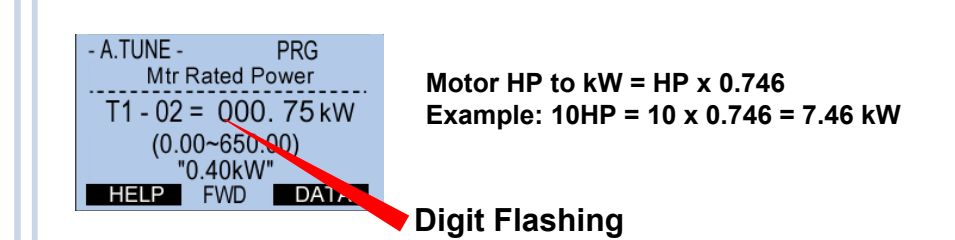

Press **RIGHT** to select the digit you would like to change and use **UP** **DOWN** adjust value and press **ENTER** to save.

Press **UP** to select the next parameter and follow the same procedure described above to adjust its value.

- T1-04 Rated Voltage (e.g. 230 V, 460 V)
- T1-04 Rated current (e.g. 11.0 A, 22.0 A)
- T1-05 Rated Frequency (e.g. 60.0 Hz)
- T1-06 Number of Poles (e.g. 4 Poles)
- T1-07 Rated Speed (e.g. 1750 rpm)

After setting parameter T1-07 press **UP** to select the Auto-Tuning start command.



**! Warning! Sudden movement hazard. The A1000 and motor may start unexpectedly during Auto-Tuning.**

**Warning! Electric Shock Hazard. High voltage will be supplied to the motor when stationary Auto-Tuning is performed. Do not touch the motor during auto-tuning.**

**Notice: Auto-Tuning will not function properly when a brake is engaged on the load. Ensure the motor shaft can freely rotate. Never perform an Auto-Tune with motor connected to a load.**

Next, press **RUN** on the Digital Operator. The A1000 will now start the Auto-tuning procedure.

The display will show message "Tune Successful" when the Auto-Tuning procedure has been successfully completed.

Please reference the A1000 User Manual or repeat the procedure again if the display shows an error message.

## Step 5 Changing Parameters and Monitoring the A1000

This step shows how to access and modify a A1000 parameter as well as how to monitor A1000 signals such as output frequency and motor current.

Make sure all protective covers have been re-attached and power is turned on. **DO NOT RUN THE MOTOR.**

### Access Parameter Menu and Change Parameter Value

Press **V** two times until the digital operator shows the parameter menu.

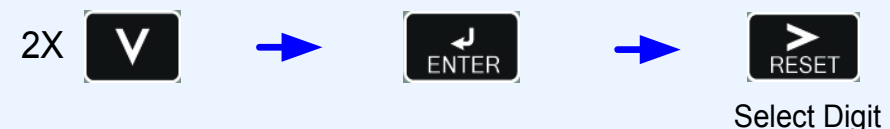
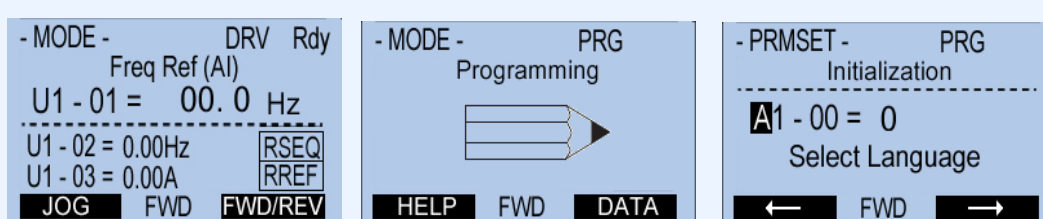

Select Digit



Go to Next Digit

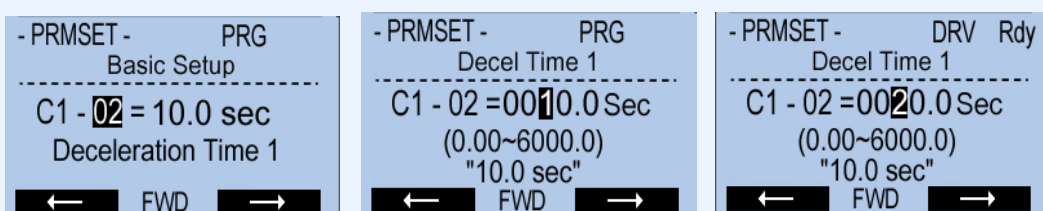

Switch to Edit Mode      Modify Value      Save New Value

### Monitor Motor Frequency and Motor Current

A1000 Digital Operator power-up state

Output Frequency and Motor Current can be monitored

simultaneously.

To monitor output frequency and motor current or other signals

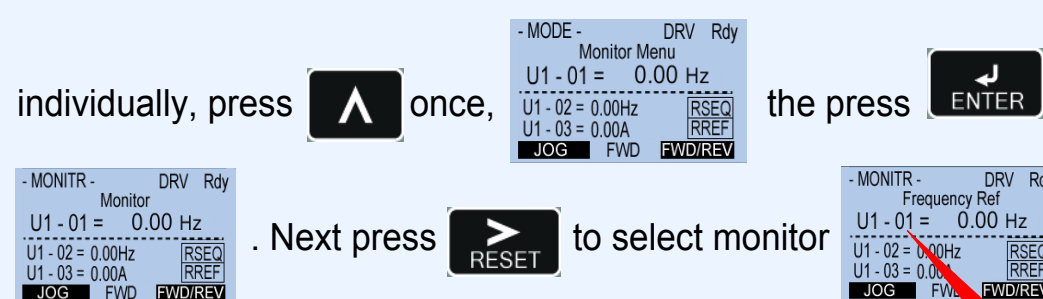

Use **V** to select monitor signal.

U1-02 Output Frequency

Please refer to the A1000 User Manual, (Document No. SIEP C710606 21A) on how to access other drive monitors.

## Step 6 Selecting Start/Stop and Speed Method

This step shows how to setup the sequence and reference method of the A1000. The sequence method determines how the A1000 drive receives its start and stop command and the reference method determines how the speed of the motor is controlled. Make sure all protective covers have been re-attached and power is turned on. **DO NOT RUN THE MOTOR.**

This section may require you to change one or more A1000 parameters. Please refer to Step 5 for a detailed explanation on how to change parameters.

### SELECT SPEED METHOD b1-01

#### 1. Adjust motor speed / frequency from the Digital Operator

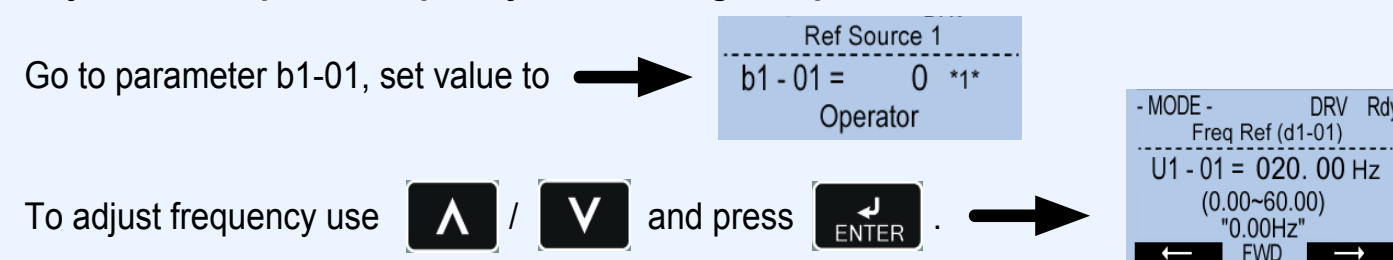

#### 2. Adjust motor speed / frequency from external terminals (0 - 10V / 4 - 20mA Signal)

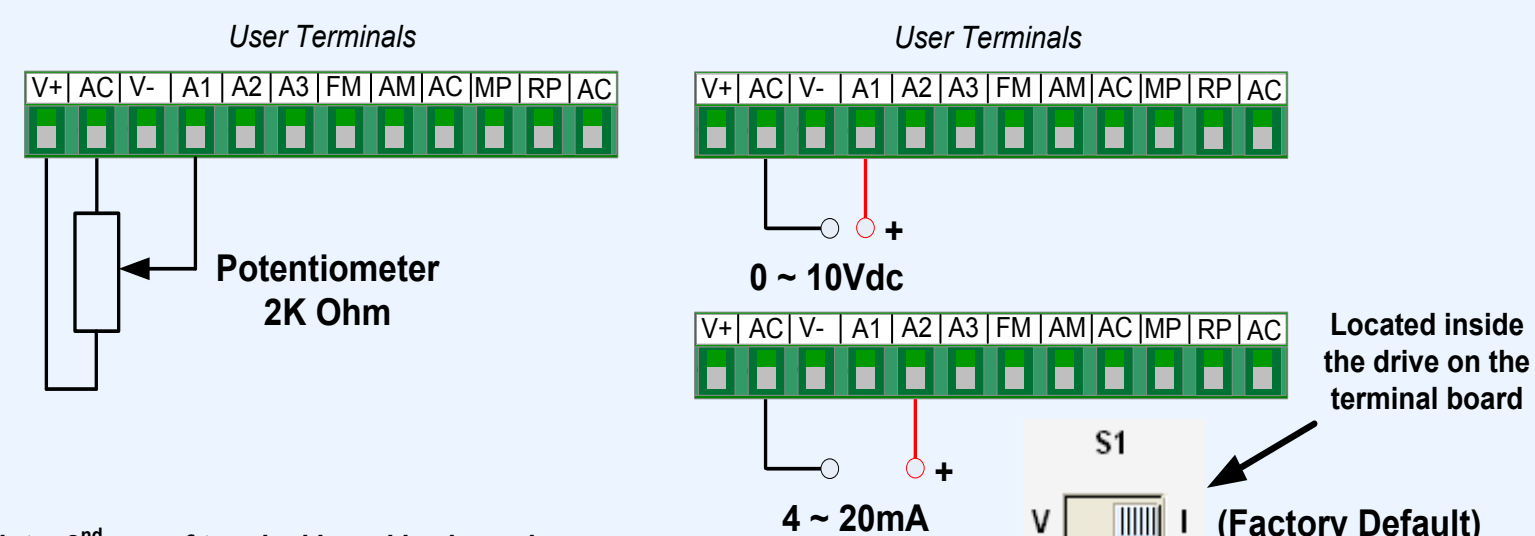
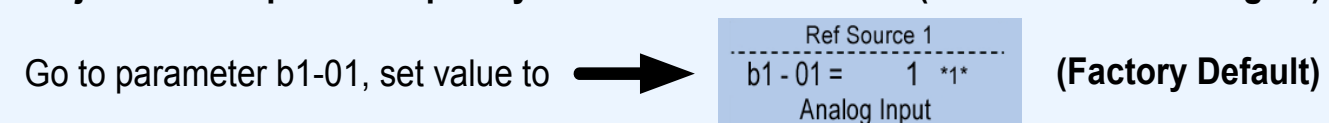

Note: 2<sup>nd</sup> row of terminal board is shown here.

### SELECT START / STOP CONTROL METHOD b1-02

#### 1. Start / Stop Control from Digital Operator

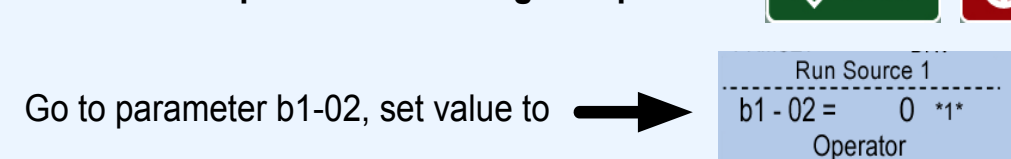

#### 2. Start / Stop Control from external terminals (switch or relay contact)

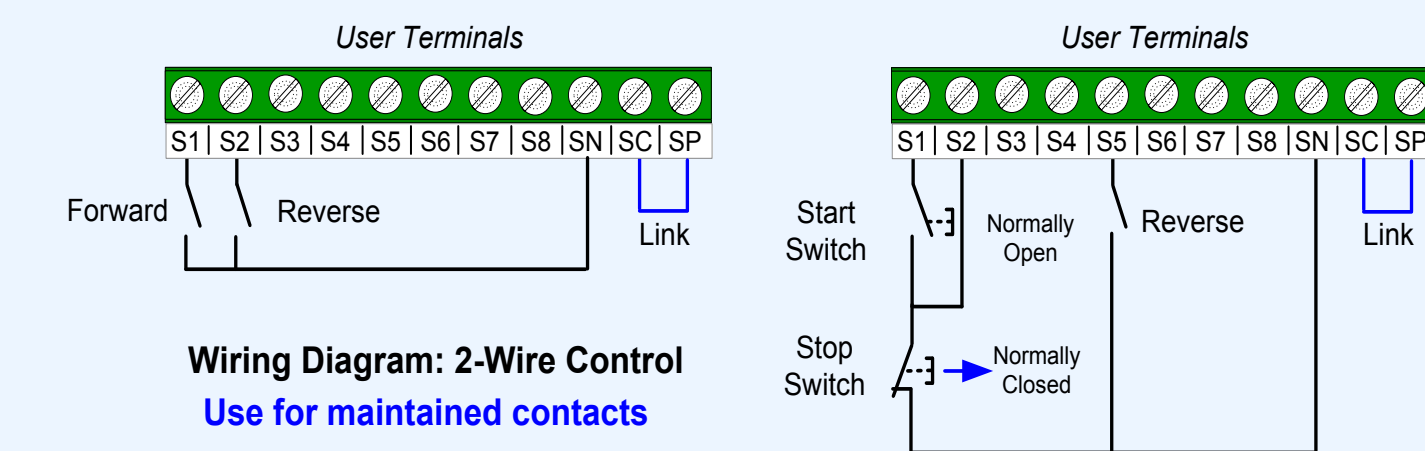
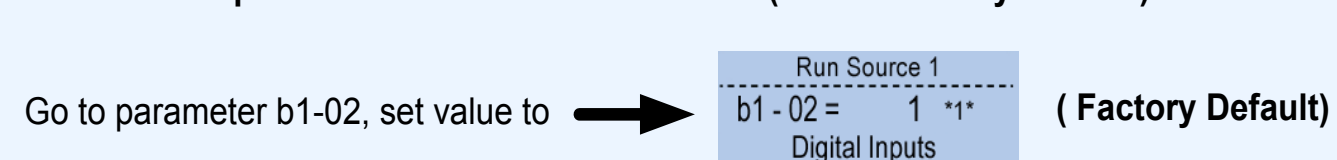

Note: 3<sup>rd</sup> row of terminal board is shown here.

NOTE: It is beyond the scope of this document to program the A1000 drive for network communication control. Please refer to the refer to the A1000 User Manual, (Document No. SIEP C710606 21A) for this selection.

## Step 7 Quick Start Parameters

The following table lists the general purpose application parameters as well as frequently asked questions.

This section may require you to change one or more A1000 parameters. Please refer to Step 5 for a detailed explanation on how to change parameters.

### GENERAL PURPOSE APPLICATION PARAMETERS

Parameter	Default Value	Description	Comments
b1-01	1	Reference Source Speed Control Method	0 = Digital Operator (Adjust Motor Speed from keypad) 1 = Terminals (Speed Pot. / 0 - 10V / 4-20mA)
b1-02	1	Run Source / Start/Stop Control Method	0 = Digital Operator (Start/Stop motor from keypad) 1 = Terminals (Start/Stop using external contact / switch)
b1-03	1	Stop Method Selection	0 = Ramp to stop (Motor ramps down at stop command) 1 = Coast to stop (Motor freewheels at stop command)
b1-04	0	Reverse Operation	0 = Allow motor to run in reverse direction 1 = Reverse direction prohibited
C1-01	10.0 sec.	Acceleration Time	The time it takes to ramp up from 0 to maximum motor speed.
C1-02	10.0 sec.	Deceleration Time	The time it takes to ramp down from maximum motor speed to 0.
C6-01	0	Heavy / Normal Duty	0 = Heavy Duty (Use for conveyor, mixer, applications) 1 = Normal Duty (Use for fan and pump applications)
d1-01	0.00 Hz	Frequency Reference	Frequency setting when speed is set from the keypad.
d2-01	100.0 %	Frequency Upper Limit	Maximum motor speed allowed (e.g. 100 % = Max rpm)
d2-02	0.0 %	Frequency Lower Limit	Minimum motor speed allowed (e.g. 100 % = Max rpm)
E2-01	*	Motor Rated Current	Motor nameplate current
L1-01	1	Motor Overload Selection	0 = Disabled 1 = Standard Fan Cooled Motor 2 = Standard Blower Cooled Motor 3 = Vector Duty Motor
L1-02	1.0 min	Motor Overload Time	Sets the motor thermal overload protection time.

### FREQUENTLY ASKED QUESTIONS

**Question:** How do I reset the drive back to factory default settings?

**Answer:** Go to parameter A1-03 and set value **2220** for 2 wire control or **3330** for 3 wire control (Please refer to Step 6 for wiring diagram)

**Question:** How do I adjust the time it takes the motor to speed up or slow down?

**Answer:** Adjust the acceleration time parameter C1-01 and deceleration time C1-02.

**Question:** How do I prevent my drive from tripping on an **OV** fault (overvoltage) while my motor is ramping down?

**Answer:** Increase deceleration time parameter C1-02.

**Question:** How do I prevent my drive from tripping on an **OL1** fault (overload) while my motor is ramping down?

**Answer:** Verify motor rated current parameter E2-01 and motor overload parameter settings L1-01 Motor overload selection, L1-02 Motor overload protection time.

**Question:** I want to run my motor above the nominal motor speed?

**Answer:** Increase the value of parameter E1-04 Maximum Frequency  
**Warning! Verify that the motor and system allow for this.**